

309BM - MAGNETIC LEVELS



Standards :

DIN 877

Description :

- In reverse position, accuracy 1 mm/m.
- Light alloy body, drawn.
- Smooth anodized surfaces (easy cleaning).
- Vertical vial and horizontal vial.

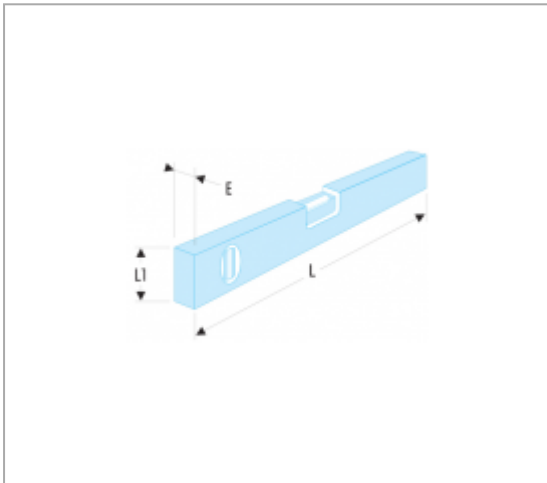

References :

	E [MM]	L [MM]	L1 [MM]	[G]
309BM.40	21	400	50	300
309BM.60	21	600	50	80