

AIR NIBBLER

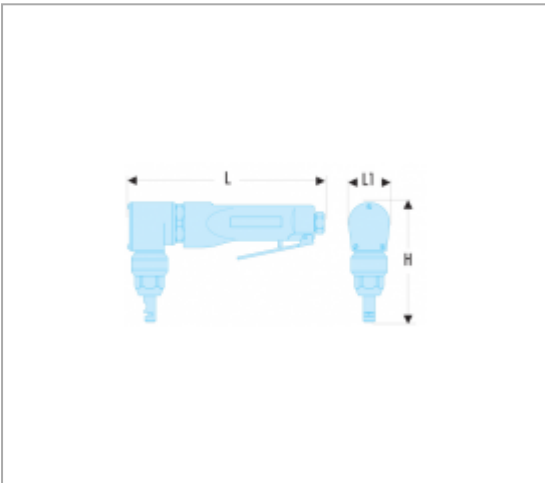

Description :

- Lever throttle for precise control and low-speed start.
- Easy access to replace the punch: V.850FKR2.
- Can produce rounded edges up to 6.5 mm radius.
- Can cut 1.8M of sheet metal per minute at a max depth of 1.2 mm.
- Durable motor design encased in a strong and robust aluminium housing.
- Blows per minute 4300 cpm.
- Working pressure 6,2 bar.
- Average air consumption 280 l/min.
- Average air consumption 9,6 cfm.
- Air inlet 1/4".
- Minimum hose diameter 10 mm - 3/8".
- Vibration 6 m/s²/a.
- Vibration 1,09 m/s²/K.
- Sound pressure 95,90 dB(A).
- Sound power 106,90 dB(A).
- Available as accessory: - Punch set: V.850FKR2.



References :

	H [MM]	L [MM]	L1 [MM]	[KG]
V.850F	118	179	40,5	1